

Introduction to LasrPlay and DVDplay Synchronizers



Multi-channel Synchronizers and Controllers for
Pioneer Laserdisc and DVD Video players

Dave Jones Design



Dave Jones Design

87 Chestnut St., Owego, NY 13827 USA

tel: (607) 687-5740

fax: (607) 687-5898

e-mail: info@djdesign.com

web: www.djdesign.com

Last updated 4/6/2000

All images and information contained in this booklet are intended for viewing by customers and potential customers of Dave Jones Design. This booklet is copyright 1993, 1995, 1997, 1998, 1999, 2000 by David R. Jones & Dave Jones Design, with all rights reserved. Reproduction of any kind is prohibited without the express written permission of David R. Jones or Dave Jones Design.

LasrPlay and DVDplay are trademarks of Dave Jones Design.

© 1993, 1995, 1997, 1998, 1999, 2000 David R. Jones / Dave Jones Design

Introduction to LasrPlay and DVDplay Synchronizers

Table of Contents

Introduction	1
Sync vs. Synchronization	1
A Typical System	3
How It Works	3
Before Using the DVDplay	4
Models	5
Optional Extras	5
Players	6
Discs	6
Electricity	7
Specific Models	7
Connectors and Controls	8
Programming the synchronizers	10
Installing the synchronizers	10
Part Numbers and Ordering	11
LasrPlay Specifications	12
DVDplay Specifications	13

INTRODUCTION

This booklet describes in detail the LasrPlay and DVDplay series of synchronizers from Dave Jones Design. These two series of devices are very similar, but have a few differences. Most of what is in this manual holds true for both the LasrPlay series and the DVDplay series. When there are specific differences, they will be pointed out by naming the appropriate series. When the text refers to a “synchronizer”, it is referring to both the LasrPlay and the DVDplay. The main difference between them is that the LasrPlay series is designed specifically to work with the Pioneer industrial laserdisc players, while the DVDplay is designed for use with Pioneer’s industrial DVD players.

These synchronizers are intelligent, programmable controllers for use with Pioneer brand industrial laserdisc and DVD players. Their function is to play a section of a disc (or multiple discs) in a continuous loop. In systems with multiple channels of video, each channel can be programmed to start playing at the same time as the rest of the channels, or be set to play in a loop by itself. This synchronization of multiple images is extremely accurate and can be used to make several channels of video look like parts of a single larger image. These are not general purpose controllers that work with a computer to script a complex show, their sole purpose is to play a single loop over and over again with the channels synchronized to each other.

The LasrPlay was originally developed for use in laserdisc based video art exhibitions, and they are installed in museums around the world. Their ease of use and high reliability have been praised by many artists, curators, and installers. Artists and engineers like them because they are so easy to program and install, and curators like them because all they have to do is turn the power on in the morning and the exhibition starts automatically. The DVDplay uses the same hardware design as the LasrPlay but has new firmware for controlling Pioneer’s industrial DVD players.

SYNC vs. SYNCHRONIZATION

Let’s take a moment here to understand that there are two different types of “synchronization” happening in some LasrPlay and DVDplay

systems, and it is important to understand the difference. The LasrPlay and DVDplay are synchronizers in the sense that they play sections of several discs so that a specific frame of video on one disc starts playing at the same time as a specific frame of video on another disc (or several discs). This is something you can see visually on several monitors playing those channels of video.

The other type of synchronization is invisible to the naked eye and requires test equipment to see it, though it can affect the accuracy of the first type. If you understand how video works, you know that the image is scanned onto the monitor starting at the top left corner of the screen and scans across to the right side over and over again, each time a little lower on the screen.

The part of the video signal that tells the monitor to start scanning at the top of the screen is known as vertical sync. The part of the video signal that tells the monitor to start scanning each scan line on the left side of the screen is known as horizontal sync. There are a lot of horizontal sync pulses (one per scan line) for every vertical sync pulse. Certain video devices can be fed an external sync signal to force their video signals to start vertically (and sometimes horizontally) at the same time. You can't see this with your eyes, but if the video signals go into a switcher, it may require this type of synchronization.

Pioneer's industrial DVD players accept a "black burst" signal to force it's video output to start scanning in sync with other players that also have this signal going into them. Pioneer's 4000 and 8000 series of industrial laserdisc players accept a "composite sync" signal for this same purpose. The 2000 series of laserdisc players do not have the ability to accept external sync. Black burst and composite sync both carry vertical and horizontal sync information to the player, but they are not the same type of signal.

The LasrPlay synchronizers are available with an optional composite sync output and the DVDplay is available with an optional black burst output. By feeding these signals to the players you are locking the internal electronics of the players so that the video outputs scan at the same time, and the players internal computers are communicating with external devices at the same time.

By using these options you are increasing the accuracy of communication and therefore the accuracy of the start of the playback loops on the players. Without this option the playback will still appear

to start at exactly the same time but in reality it may be off by as much as a frame of video (1/30th second in NTSC or 1/25th second in PAL). Most video installations don't require using these options because it is visually hard to detect a frame of video, but the most exacting installations should probably have this option.

A TYPICAL SYSTEM

A typical system consists of a multi-channel synchronizer hooked up to a number of Pioneer industrial players (though there is a one channel version available for times when you only need to play a loop on a single player). Each of the players will be connected to a video monitor or projector. Some (or all) of the players might also be connected to audio amplifiers and speakers. There is no

central computer required in this system because the synchronizer has its own computers to control the players. The cables needed to connect the synchronizer to the players are included with the synchronizer.

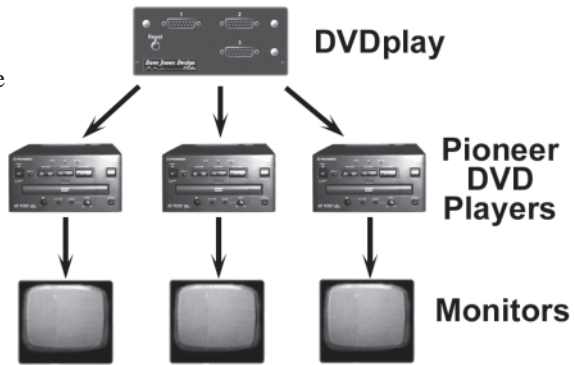

figure 1. - a typical system

HOW IT WORKS

The synchronizer must be programmed at least once prior to use (either at the factory or by the user). This can be done with any IBM style PC computer (it doesn't have to be an IBM brand) using the software and cable supplied with the synchronizer. Once programmed it no longer needs any external computers to control it. Each channel of the LasrPlay or DVDplay synchronizer has its own high speed RISC computer that communicates with an individual Pioneer player. This means that, for example, a 5 channel device has 5 small fast computers in it to control the 5 players. Because each computer only

has to control a single player, and all of the computers talk to each other over an internal network, the control and synchronization is very fast and accurate.

On power-up, the synchronizer will take control of the player through it's serial port and, if there is a disc inside, it will spin up to speed. If there is no disc inside, the drawer will automatically open until a disc is inserted. Once the disc is up to speed, the synchronizer will seek out the starting frame number of the loop to play. When the starting frame has been reached, each channel checks an internal network to see if every other channel is ready to play. If not, the channel waits for the rest of the channels to get ready. Once all synchronizer channels have reached their starting frames, they all start playing at the same time.

When the playback loop is started, all channels of the synchronizer send the command to start playing to all their players at exactly the same time. Once they start, they will stay synchronized for the duration of the playback. When each disc reaches their ending frame number of the loop, the picture and sound are blanked out and they once again seek out the starting frame number and re-synchronize for the next playback loop. If the channels are programmed to play different length segments on each disc, each player will go blank at the end of their particular loop and then wait for the rest of the players to finish. If any of the channels have been programmed not to synchronize, they will start playing their loop over again as soon as they are done without waiting for the rest of the channels.

There is a small delay between the end of the loop and the start of playing the loop again. This delay is dependant on the search speed of the player and the disc used, and in the case of the DVDplay, whether you programmed it to search on a title, chapter, timecode or a frame number. Searching on a title or chapter is faster than searching on a timecode or frame number, but only by a second or two.

BEFORE USING THE SYNCHRONIZER

Before a LasrPlay or DVDplay synchronizer can be used it must be programmed with the specific information for your discs and players. This programming can be done for you by us using information that you supply, or you can do it yourself using the supplied software and programming cable. You can also reprogram it

at any time yourself even if we did it for you the first time.

The synchronizer is programmed using an IBM style PC computer. It does not have to be an IBM brand computer, any compatible PC computer will work. The synchronizer comes with a 3 1/2 inch floppy disk (or CD on special request) that contains programs that are used to set parameters in the synchronizer. Once it is programmed, the synchronizer does not require an external computer to operate since it has it's own onboard computers that control the players.

A number of parameters must be programmed into the synchronizer for it to operate correctly. These include the starting frame number, the ending frame number, and the speed of the serial port in the player. Several optional modes and settings can also be programmed into the synchronizer. These include locking out the front panel controls to prevent tampering with the system, as well as other options. Refer to the specific programming manual for the LasrPlay or DVDplay for step by step instructions on programming them.

MODELS

There are many models in the LasrPlay and DVDplay series, but it is easy to remember the different model names. Just add the number of channels after the name. This means, for example, that the DVDplay-2 is a 2 channel DVD synchronizer while the LasrPlay-2 is the same thing for laserdisc players. There is no limit to the number of channels that can be built into a LasrPlay or DVDplay unit because every channel has it's own computer, so a DVDplay-25 would have 25 channels. In addition to the number, there may be letters at the end of the model number to define options that were ordered. See the tables at the end of this booklet for exact model numbers.

OPTIONAL EXTRAS

There are a couple of optional features that can be built into a synchronizer. Most installations do not require these options. As mentioned earlier, the DVDplays can be made with an optional Black Burst output and the LasrPlays can be made with a similar option which puts out composite sync. These options allow more accurate synchronization as well as locking the images to the vertical interval,

which is useful when the images are going into a video switcher. Any standard sync generator that puts out these signals will work, but it is often easier (and cheaper) to have this built into the same box as the DVDplay.

The synchronizers can also be made with an option known as a “network connector” which is used to tie together two or more synchronizers to make them act like one large synchronizer. Even though this is called a “network” connector, it is not a computer network. It is an extension of the proprietary internal network that channels use to synchronize with each other. It can also be used to keep the channels from starting a playback loop. By connecting this to a switch or contact closure that shorts the pins together, you tell the synchronizer to not start. Once the switch is pushed or contacts opened, playback starts.

PLAYERS

The DVDplay is compatible only with Pioneer industrial DVD players and the LasrPlay is compatible only with Pioneer industrial laserdisc players. The DVDplay supports Pioneer’s DVD-V7200, 7300, and 7400. There are a number of current and older industrial laserdisc players that will work with the LasrPlay. These include all models in the 2000, 4000, 5000, and 8000 series, except the 2000E which does not have a serial port.

DISCS

The DVDplay is designed to work with DVD-Video discs, whether they are mass produced or DVD-R custom recordings. It is not designed to work with Video-CD, which the industrial players will also play. Video-CD is an old non-DVD format used primarily in Japan with MPEG-1. DVD-Video is the DVD format that uses MPEG-2.

The LasrPlay is designed to work with CAV type laserdiscs, though a CLV version is available by special order. The CAV discs can hold up to 30 minutes of NTSC or 36 minutes of PAL video. CLV can hold a longer period of time, but CLV discs can not be synchronized accurately. They are OK if you don’t mind the channels being off by as much as a second from each other.

ELECTRICITY

The LasrPlay and DVDplay run off of 100-125 or 220-240 volts (which is switchable on the back with a small screwdriver). All of our synchronizers are supplied with a detachable American standard power cable for 110 volt use. They use the standard international IEC power connector on the back of each unit, so a local power cable can be purchased in almost any country in the world. These are the same power cables used by computers, printers, and many other electronic devices.

SPECIFIC MODELS

There are a lot of different models of LasrPlay and DVDplay synchronizer. The connectors and controls are the same between the two series and are described in detail in the following section. 1, 2, and 3 channel synchronizers come in small boxes that are about twice as thick as an external modem. The larger models come in rackmount boxes that fit in standard 19 inch equipment racks, though they can have the rack mounting brackets removed if you simply want them in a box to place on top of other machines. Synchronizers with 4 through 7 channels come in "1RU" (one rack unit) boxes which are 1 3/4 inches tall. Synchronizers with more channels come in taller rackmount boxes.

The 1, 2, and 3 channel models don't have a power switch because they use a fraction of a watt of power, and in most installations they are plugged into a power strip along with the players, so all devices get turned on and off from the strip. When you plug them in the lights on the front will start by glowing red so you know they are working. The rackmount versions have a power switch mounted on the front so they can easily be turned off (power cables in equipment racks are traditionally hard to get to).

The other controls and options are the same between the smaller units and the rackmount units except that the small units have the player connectors on the front while the rackmount models have them on the back.

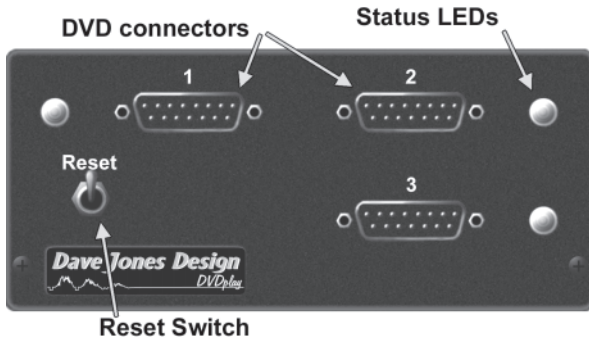

figure 2. - DVDplay-3 front panel (same as LasrPlay-3)

CONNECTORS AND CONTROLS

Power Switch (only on rackmount units) - To turn the synchronizer on and off. This lights up when the unit is on.

Reset Switch - Pressing this momentary toggle switch will reset the synchronizer. All channels will pause for 7 seconds and then start up as if power had just been turned on.

Status LEDs - The multi colored status lights provide some feedback to the user as to what the synchronizer is doing.

GREEN = playing

RED = initializing

ORANGE = programming (or not connected)

OFF = synchronizing or waiting to start the loop

Player Connectors - The 15 pin D-shell connectors are connected to the programming cable during programming, and are connected to

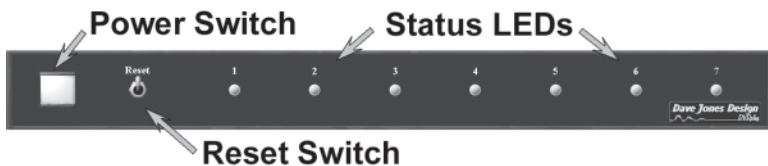

figure 4. - DVDplay-7 front panel (same as LasrPlay-7)

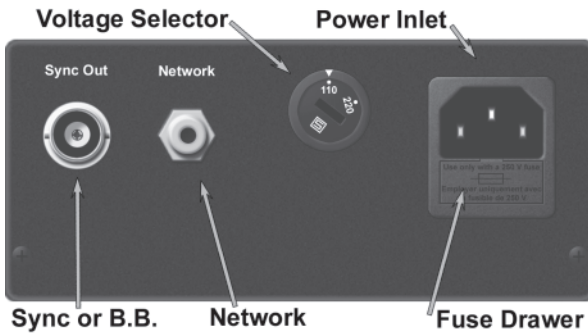

figure 3. - DVDplay-3 back panel (same as LasrPlay-3)

the Pioneer players during normal operation. This is the serial control signal that tells the player what to do.

Voltage Selector - This is a rotary switch that can be changed by inserting a small screwdriver in the slot and turning. The voltage selector chooses between 100-125 volts and 220-240 volts. The voltage does not have to be precise, the switch just selects the voltage range.

Power Inlet - The power cord gets plugged in here. The fuse is also inside this part. The fuse can only be removed when the power cord is not plugged into the power inlet. The fuse is inside a small drawer that can be opened with a fingernail or small screwdriver. The fuse is a 5x20mm, 0.3 amp slow blow type of fuse. When running only on 220-240 volts, this can be a 0.15 amp fuse. The synchronizers have internal surge protectors that will cause this fuse to blow if the input voltage goes above 130 volts when set for 110 or above 260 volts when set for 220. The power cord is a standard international IEC type power cord. Replacements are available at most computer stores around the world.

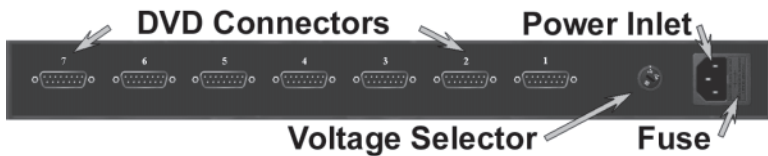

figure 5. - DVDplay-7 back panel (same as LasrPlay-7)

Comp Sync/Black Burst Out (optional) - This is an optional video reference signal output that is fed to the ext. sync input on certain Pioneer players to ensure that the video outputs are locked at the vertical interval. When this option is installed, it is done with a BNC connector on the back panel.

Network Connector (optional) - This can be used to connect multiple LasrPlay or DVDplay synchronizers to each other to make a larger synchronizer. It can also be used as a way to externally start the playback loop. As long as this connector is shorted with a “normally closed” switch or a set of contact closures from a relay or external device, the synchronizer will not start playing it’s loop. Once the contacts are opened the synchronizer will start it’s playback loop. It will continue to play the loop even if the contacts are closed again, but will not start the next loop if the contacts are closed by the time the synchronizer is ready to play the next loop. When this option is installed, it is done with an RCA (phono) connector on the back panel

PROGRAMMING SYNCHRONIZERS

You only need to program the synchronizer if it was not done for you when you ordered it or if you want to adjust some of the parameters. This is done using the included programming cable and software. The software is only available in PC format. For specific instructions on programming the synchronizers, refer to the booklets “LasrPlay Programming and Installation Manual” and “DVDplay Programming and Installation Manual”.

INSTALLING THE SYNCHRONIZER

Step by step instructions for installing the synchronizers can be found in the Programming and Installation Manual for the specific synchronizer. It is fairly simple. Once it is programmed, the synchronizer is simply connected to power and to the players using the supplied cables. After that just turn on the power and walk away.

The only problem that installers sometimes have is forgetting to set the BAUD rate on their players to match the BAUD rate they programmed into the synchronizer. You need to do this before using the system for the first time.

Part Numbers:

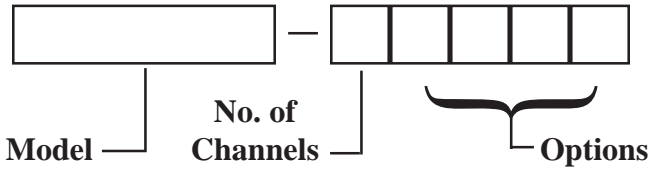

DVDplay
LasrPlay

Standard sizes are 2-7 channels, but any size can be ordered (4 channels and up come standard in rackmount box, add option “R” for 2 or 3 channel in rackmount box)

R - rackmount (2 or 3 channel only)
B - black burst out (for DVDplay)
S - comp sync out (for LasrPlay)
N - network I/O (external trigger and expansion)
CLV - for CLV discs (LasrPlay only)

Examples:

- LasrPlay-2 *basic 2 channel laserdisc synchronizer*
- DVDplay-3 *basic 3 channel DVD synchronizer*
- LasrPlay-5S *5 channel laserdisc with comp sync out*
- DVDplay-6BN *6 channel with black burst and expansion*
- LasrPlay-3CLVSN *for CLV laserdiscs plus sync out & expansion*
- DVDplay-3R *3 channel in rackmount box*

LasrPlay and DVDplay synchronizers are currently only available directly from:

Dave Jones Design tel: (607) 687-5740
 87 Chestnut St. fax: (607) 687-5898
 Owego, NY 13827 USA e-mail: info@djdesign.com

www.djdesign.com

LasrPlay Specifications:

Power Supply Voltage: 100-125, 220-240 volts 50-60 Hz

Fuse: 5x20 mm, 0.315 amp

Laserdisc Format: CAV (special CLV versions are available)

Compatible Players: All Pioneer industrial Laserdisc players in the 2000, 4000, 5000, and 8000 series except the E2000

Connectors:

Power: IEC international

Laserdisc: DB-15 male

Controls: Reset switch
Power On/Off
(only on rackmount versions)

Speeds/Times: (approximate)

Power-up: 7 seconds

Disc spin-up: 5-10 seconds (player dependant)

Synchronization: 0.5 seconds

Rewind: 1-3 seconds (player dependant)

Accessories Supplied: IEC power cable with
American connector
15 pin Laserdisc cables
6 feet long (one per channel)
Programming software
(for PC only)
Programming cable
Rack mounting brackets
(only with rackmount models)
Introduction booklet
Programming manual

Options Available: Comp. Sync output
Blackburst output
External trigger / Expansion network
(to connect multiple LasrPlay units)

specifications subject to change without notice

DVDplay Specifications:

Power Supply Voltage: 100-125, 220-240 volts 50-60 Hz

Fuse: 5x20 mm, 0.315 amp

DVD Format: DVD-Video

Compatible Players: Pioneer DVD-V7200
Pioneer DVD-V7300
Pioneer DVD-V7400

Connectors:

Power: IEC international plug

DVD: DB-15 male

Controls: Reset switch
Power On/Off
(only on rackmount versions)

Speeds/Times: (approximate)

Power-up: 7 seconds

Disc spin-up: 5-10 seconds

Synchronization: 0.5 second

Rewind: 2-10 seconds

Accessories Supplied: IEC power cable with USA connector
15 pin DVD cables, 6 feet long
(one per channel)
Programming software (for PC only)
Programming cable
Rack mounting brackets
(only with rackmount models)
Introduction booklet
Programming manual

Options Available: Blackburst output
Comp. Sync output
External trigger / Expansion network
(to connect multiple DVDplay units)

specifications subject to change without notice